

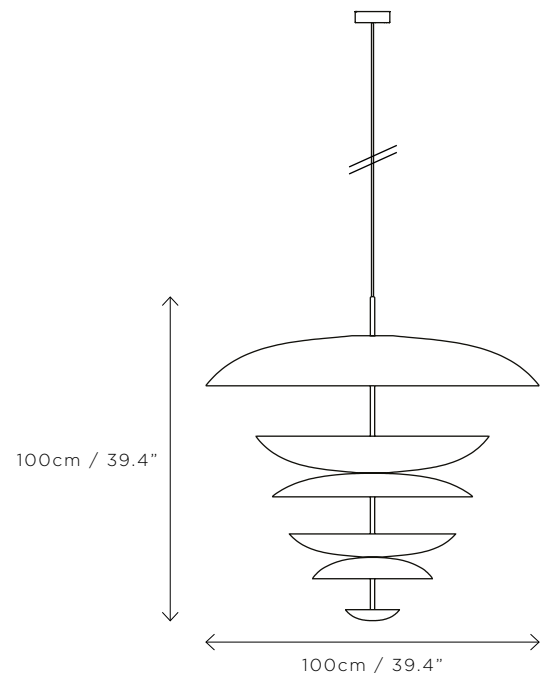

SPECIFICATIONS

DIMENSIONS	Dia. 100cm (39.4") Height 100cm (39.4")
WEIGHT	Approx. 40kg (88.2lbs)
MATERIALS	Satin brass framework Hand-spun brass plate
LEAD TIME	8-10 weeks excl. shipping
ILLUMINATION	Integrated LED (No bulb required) LED colour temperature 2700K LED dimmable driver
OUTPUT	Constant current 700mA 80W 5800 lumen
INPUT	120/240V - 50,000 hours rated life
DIMMING	Mains, DALI, 0-10V or 1-10V
CEILING MOUNTED	INTEGRATED driver - housed in product Standard 3m (118") cable cut to size Drop rod / hang straight options available
REGION	CE certified; UL listing available at a surcharge



FINISH

PURION



PURION

SELENO

M BRONZE

FRAME



S BRASS

CANOPY



S BRASS

CABLE



GOLD

STANDARD COMBINATION

SHADE

● PURION

FRAME

● SATIN BRASS

CANOPY

● SATIN BRASS

CABLE

● GOLD

CAROUSEL CHANDELIER SERIES



REGOLITH



VERDIGRIS



ORE



SEPIA