

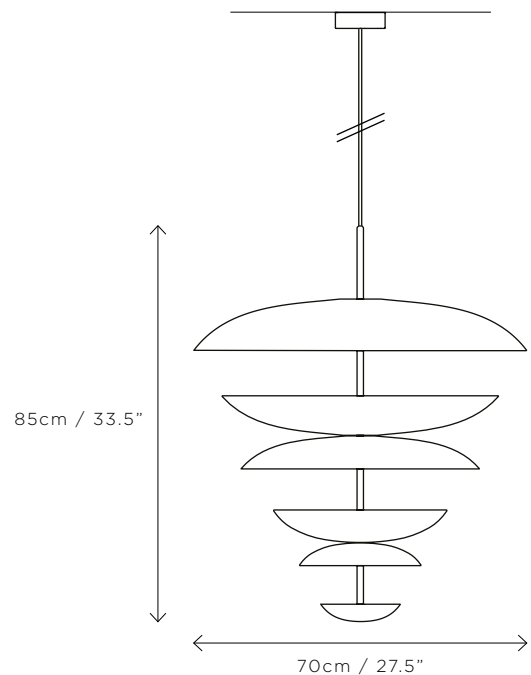

## SPECIFICATIONS

DIMENSIONS	Dia. 70cm (27.5") Height 85cm (33.5")
WEIGHT	Approx. 30kg (66.1lbs)
MATERIALS	Satin brass framework Hand-spun brass plate
LEAD TIME	8-10 weeks excl. shipping
ILLUMINATION	Integrated LED (No bulb required) LED colour temperature 2700K LED dimmable driver
OUTPUT	Constant current 700mA 60W 4500 lumen
INPUT	120/240V - 50,000 hours rated life
DIMMING	Mains, DALI, 0-10V or 1-10V
CEILING MOUNTED	INTEGRATED driver - housed in product Standard 3m (118") cable cut to size Drop rod / hang straight options available
REGION	CE certified; UL listing available at a surcharge



## FINISH

### PURION



PURION

SELENO

M BRONZE

### FRAME



S BRASS

### CANOPY



S BRASS

### CABLE



GOLD

## STANDARD COMBINATION

### SHADE



PURION

### FRAME



SATIN BRASS

### CANOPY



SATIN BRASS

### CABLE



GOLD

## CAROUSEL CHANDELIER SERIES



REGOLITH



VERDIGRIS



ORE



SEPIA